

# Six practical ways to handle rotary airlock valve leakage

Jonathan O. Thorn    MAC Equipment

Because of the way a rotary airlock valve is designed, it's normal for a small amount of conveying air to leak back through the airlock as it feeds bulk solid material to a pressure pneumatic conveying system. But if you don't take steps to properly vent this leakage air from your equipment, it can create several problems, including slowing material flow into the airlock, releasing dust into your workplace or the environment, and disrupting your upstream process. This article describes six practical ways of arranging your pressure pneumatic conveying equipment to vent airlock leakage so you can avoid these problems.

While a rotary airlock valve is the most common valve for feeding dry bulk materials into a pressure pneumatic conveying system, it isn't a perfect sealing device. In fact, air leakage (also called *blow-by*) is inherent to the airlock's design, as shown in Figure 1, and the device leaks conveying air (or other conveying gas) at a rate proportional to the pressure differential across the airlock. The pressure below the airlock is created by resistance to flow as material is transferred.

What problems can unvented leakage air from your rotary airlock valve cause? In a pressure conveying system, the airlock feeds material near the system's start, so air leaking through the airlock vents back into the upstream process. This leakage can limit material flow into the airlock; release dust into your workplace or outdoor atmos-

phere, which can create major housekeeping or environmental problems; and pressurize upstream equipment, which can disrupt your process. To prevent these problems, you need to find a way to properly vent the air leaking through the airlock.

Six practical methods for venting leakage air are detailed in the following sections. The information provided for each method outlines its benefits and risks and provides recommendations for using the technique. While no single

**Figure 1**

## Air leaking through a rotary airlock valve

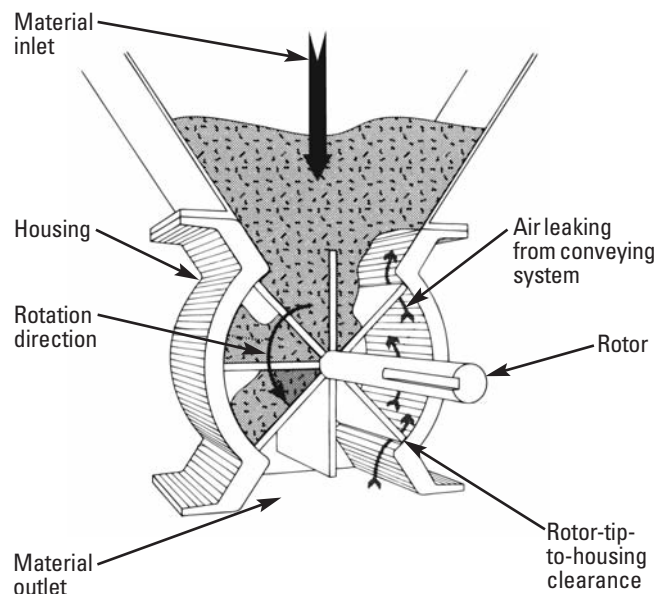

venting method will work for all pressure conveying systems, analyzing your available equipment, your material's characteristics, and your conveying conditions can help you find the right one for your application.

The venting methods described here focus on dilute-phase pressure conveying systems, although they can also be applied to dense-phase (piston-flow) pressure systems that use rotary airlock valves. In the following information, conveyed materials are classified as pellets (unfluidizable particles larger than 800 microns), granules (particles with poor fluidization between 150 and 800 microns), and powders (fine, fluidizable particles less than 150 microns in size).

## 1 Direct connection to storage vessel

In this venting method, as shown in Figure 2, the rotary airlock valve is attached directly to the vessel storing the material supplied to the conveying system, and the valve acts both as an airlock and a metering device to the conveying line. The air leaking through the airlock is released directly into the storage vessel, passes through the stored material, and exhausts from the vessel's top. The vessel often has a bin vent filter (a large dust collector with bag or cartridge filter elements) that exhausts the relatively small volume of leakage air from the vessel after removing entrained particles from it.

**Benefits.** This is the simplest method for venting leakage air and requires the least amount of equipment and headroom. The method is ideal for a conveying system handling pellets (shown at A in Figure 2) because pellets are often very porous, allowing the leakage air to pass easily through the material in the vessel toward the exhaust. The method also works for fluidized powders, which are also porous. In this case, adding fluidizing air to the storage vessel (B) to maintain the powder fluidization allows the leakage air to mix with the fluidizing air and pass easily through the material to the exhaust.

**Risks.** The method isn't suited to venting leakage air from a system handling granules or unfluidized powders, which have very low porosity. With these materials, the static head of material in the storage vessel above the airlock would cause a pressurized gas "bubble" to form over the airlock. This could significantly impede material flow into the airlock — if not entirely stop it — greatly reducing the airlock's fill efficiency and, in turn, reducing the conveying system's transfer rate. The same problems can result when this method is used with conveying systems operating at over 8 psig, because the higher differential pressure across the airlock increases the leakage air volume. When operating at over 8 psig with lighter-bulk-density pellets, granules, or powders, the leakage air's upward velocity through the airlock's material inlet can similarly restrict the material flow and reduce the airlock's fill efficiency. In such a case, the conveying system often finds an equilib-

Figure 2

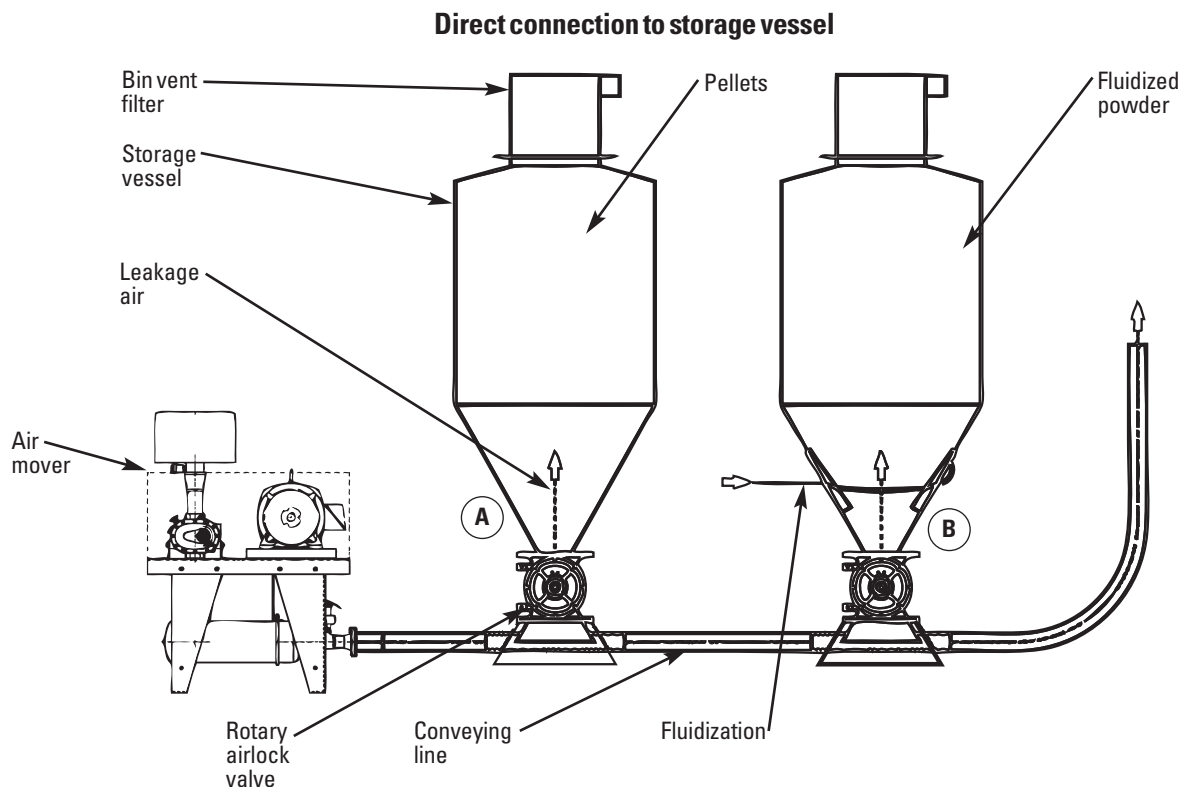

rium where the restricted material flow reduces the conveying pressure (and leakage air volume) to a level that maintains system operation, but often at a reduced transfer rate.

**Recommendations.** Use this method only for a conveying system that's designed to operate at less than 8 psig and that handles flood-fed pellets or fluidized powders that are flood-fed from a vessel with added fluidizing air.

## 2 Vented surge hopper

In this method, the rotary airlock valve is equipped with a surge hopper with a dedicated vent filter (a small dust collector) to clean the leakage air, as shown in Figure 3. The vented surge hopper, which is sized in proportion to the airlock, can be fed by another rotary airlock below a storage vessel, can be flood-fed from a storage vessel, or can serve as the transition to a metered feedpoint. (A metered feedpoint consists of a mechanical means for delivering material to the feedpoint, whether by a mechanical conveyor, a metering device, or a process vessel such as a dryer or mixer that delivers a metered feed.)

**Benefits.** As long as it's used correctly, this method is often the surest way to direct leakage air to the atmosphere. When the surge hopper is fed from a second rotary airlock (shown at A in Figure 3), the surge hopper acts as a pass-through unit and can become slightly pressurized to force the leakage air to exit through the hopper's vent filter. When flood-fed from a larger storage device (B), the surge hopper

acts as an intermediate path for the leakage air, limiting the static head of material above the airlock. For the leakage air, passing through the surge hopper to the vent filter becomes the path of least resistance. When the surge hopper is fed from a metered feedpoint (C), adding a fan at the vent filter's outlet will help draw the leakage air through the vent filter and capture ambient dust from the feedpoint.

*Use a vented surge hopper for a conveying system handling pellets, granules, or powders (either fluidized or unfluidized) and operating at greater than 8 psig.*

**Risks.** The most common mistake when using a vented surge hopper is to add a static sock filter, which includes no cleaning mechanism, on the vent outlet. While the sock filter works properly as long as it remains clean, when it gets dirty, the dirt creates airflow resistance that forces the leakage air to find another path out of the hopper or creates flow problems upstream and at the airlock. To avoid these problems, use a sock filter only when handling a material that contains a negligible amount of fines. Another common mistake when using a vented surge hopper is to use the flood-fed option when handling a powder. The leakage air can fluidize the powder, which will cause the material level in the surge hopper to equalize with the pressure from the static head of material in the storage vessel; this in turn will overfill the surge hopper with powder and clog the vent filter.

**Figure 3**

### Vented surge hopper

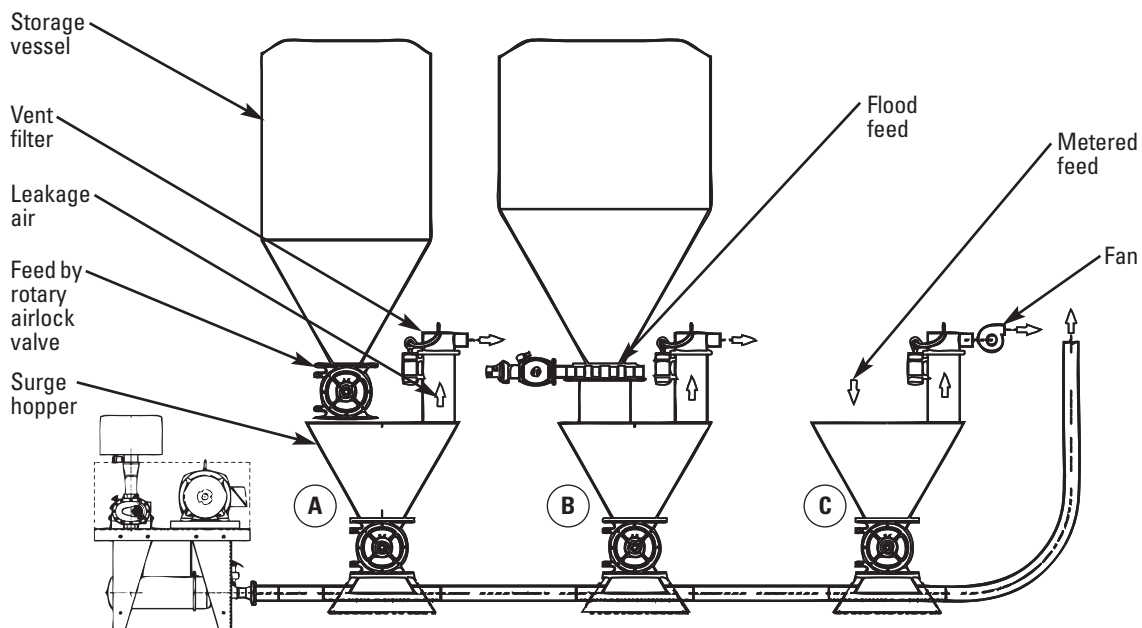

**Recommendations.** Use a vented surge hopper for a conveying system handling pellets, granules, or powders (either fluidized or unfluidized) and operating at greater than 8 psig. When handling a powder, meter the feed to the airlock, using either a secondary airlock or metered feed-point. Also use a vented surge hopper when you need to deliver material at a metered rate to your conveying system and aren't able to accurately control the feedrate with a standard airlock arrangement.

### 3 Vent pipe to storage vessel top

In this method, the leakage air is removed from the material by a vented surge hopper that doesn't have a dedicated vent filter, as shown in Figure 4. Instead, a vent pipe is coupled to the hopper's vent stub and runs to the top of a storage vessel that fills material into the surge hopper. When the material is fed from the storage vessel into the hopper through a rotary airlock valve (shown at A in the figure), the leakage air exits through the vessel's bin vent filter. When material is flood-fed from the storage vessel (B), a fan is added to that vessel's bin vent filter to create a negative draw on the vessel, which helps exhaust the leakage air.

**Benefits.** This method allows the leakage air to get to the storage vessel's top through a vent pipe without having to pass through the stored material. This alleviates some of the concerns discussed under method 1, including the potential for creating a pressurized gas bubble above the airlock that slows or stops material flow.

**Risks.** The vent pipe's diameter and routing are very sensitive to the conveyed material and the conveying system's operating conditions. In this method, the leakage air volume from the airlock serves as the conveying medium for particles entrained in the leakage air, and so these particles must be conveyed successfully through the vent pipe using this leakage air volume. However, the leakage air volume fluctuates with conveying pressure, making it inherently unreliable as a conveying medium. The result can be a plugged vent pipe. A vent pipe routing with all steep vertical angles can alleviate this problem by allowing material that hasn't been successfully conveyed through the vent pipe to flow by gravity back down the pipe to the surge hopper rather than plug the pipe. For this reason, it's best to avoid using a horizontal vent pipe.

Leakage air in the flood-fed arrangement (B) tends to entrain the most particles, regardless of the material handled, but especially with a powder. That's why the flood-fed vessel requires a fan: The fan creates a negative draw on the vessel that prevents vent pipe plugging. But the vent pipe is a hard connection (that is, a connection that doesn't allow any ambient air into the pipe), which will limit the conveying air volume in the vent pipe to that leaked only from the airlock. To solve this problem, you can use a soft connection (the *lateral connection* in Figure 4), which joins two pipes — one from the surge hopper vent and one open to the atmosphere — into one vent pipe that leads to the storage vessel. The lateral connection allows the vent pipe to continuously draw enough ambient air from the atmosphere to successfully convey the leakage air's entrained

Figure 4

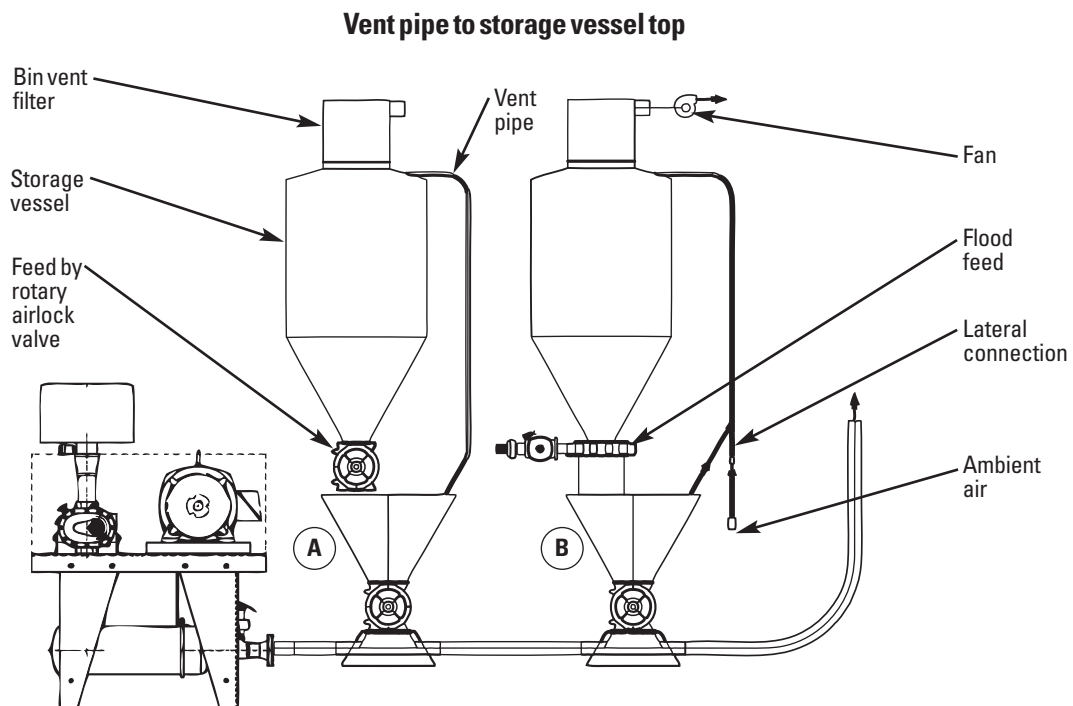

particles through the vent pipe while still capturing the leakage air and entrained particles from the surge hopper.

**Recommendations.** If you're handling pellets or granules and your storage vessel doesn't have a fan, you can use the vessel arrangement with the rotary airlock valve (A), or, if the vessel has a fan, you can use the flood-fed arrangement (B). If you're handling pellets with negligible fines, you can use the vessel arrangement shown in A but without the airlock below the storage vessel.

## 4 Central dust collection

With this method, a plant's central dust collection system collects the leakage air along with any entrained particles from the rotary airlock valve's vented surge hopper. The dust collection system fan supplies a negative draw to ensure that the leakage air follows a path through the surge hopper and its vent into the dust collection system, as shown in Figure 5. The vented surge hopper, which doesn't include a dedicated filter, provides the initial separation of entrained particles from the leakage air before the air is drawn into the dust collection system.

**Benefits.** Unlike method 3, this method doesn't rely on the leakage air volume as the conveying medium for particles entrained in the leakage air. The negative draw from the dust collection system fan makes the route out of the surge hopper's top the path of least resistance for the leakage air. The

central dust collection system can also serve all the airlock feedpoints in a conveying system with multiple feedpoints.

**Risks.** The most common mistake in applying this system is using a hard pipe connection to the surge hopper vent, which allows the dust collection system to draw only the air volume released by the airlock. This limits the system to using only that volume for handling any entrained particles, which can potentially cause vent pipe plugging. A soft pipe connection at the surge hopper vent, such as those shown at A and B in Figure 5, allows the dust collection system to draw ambient air. This allows the dust collection system duct to draw in the leakage air volume and additional ambient air required to maintain sufficient duct velocities. At A in Figure 5, the soft connection is a larger pipe surrounding, but not coupled to, the vent stub, with the larger pipe open to the atmosphere. At B, the soft connection is the same one shown in Figure 4, where two pipes join paths at a lateral connection, with one pipe open to the atmosphere.

Even when this central dust collection method is used correctly, one drawback remains: The entrained particles in the leakage air collected by the dust collection system are often discarded as waste, which is inefficient. For handling a high-value material, another method for venting leakage air would be a better choice.

**Recommendations.** Use this method with a conveying system handling pellets, granules, or powders when your

Figure 5

### Central dust collection

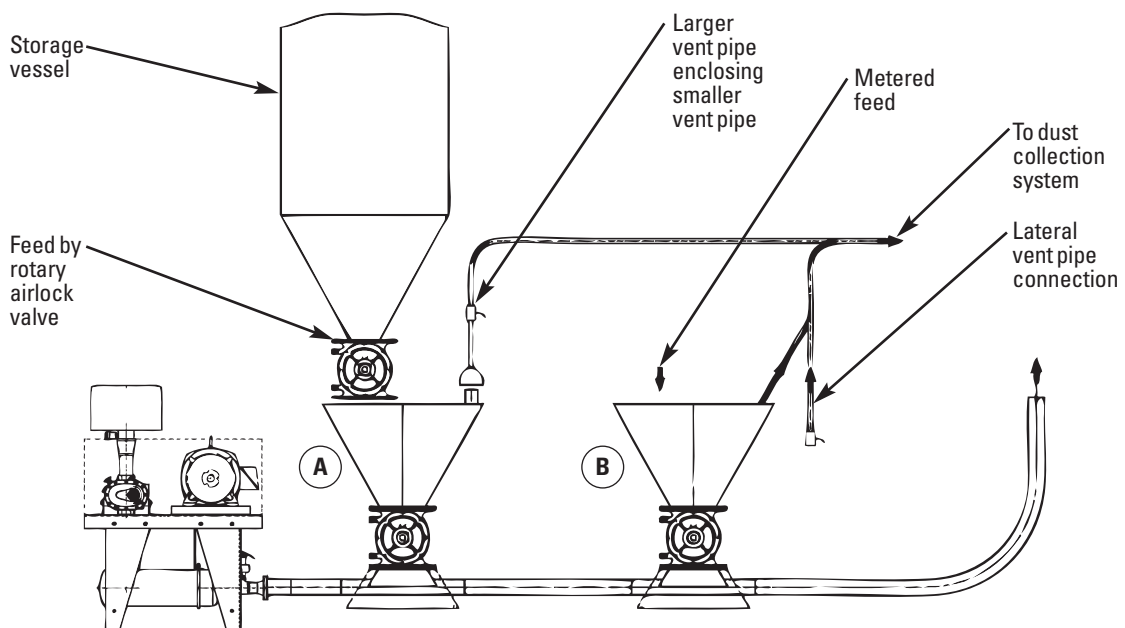



plant has an existing dust collection system. Exceptions are when you're handling a high-value material that should be captured and reclaimed, and when you're flood-feeding powder to the surge hopper, because the dust collection system can draw material from the surge hopper in addition to particles entrained in the leakage air.

## 5 Eductor-driven capture

This method uses an *eductor* on the vent pipe from the rotary airlock valve's surge hopper to capture — rather than vent — the leakage air, as shown in Figure 6. The eductor, which is a venturi device that uses pressurized gas to create a vacuum, draws leakage air and entrained particles from the surge hopper into the eductor housing and then positively conveys motive air (typically from an air compressor) along with the leakage air and entrained particles to a desired destination. This destination can be the conveying line (at A in the figure) or the top of a storage vessel supplying the surge hopper (B).

**Benefits.** This method uses a dedicated device — the eductor — to capture the leakage air and entrained particles and then transfer the mixture of leakage air, entrained particles, and motive air to the desired location. The method provides the necessary conveying air volume to handle heavier material loadings than some venting methods previously discussed.

**Risks.** An eductor is inherently inefficient because of the required supply pressure in these applications. In Figure 6,

both eductors use compressed air as the motive air, and the required volume can be substantial. The arrangement where the eductor injects the mixture of leakage air, entrained particles, and motive air into the conveying line (A) is limited to use with conveying systems operating at less than 5 psig.

**Recommendations.** Use an eductor for a conveying system handling pellets, granules, or powders at an operating pressure under 8 psig when compressed air is available as a motive air source and other leakage air venting methods are undesirable. Use the eductor primarily to convey the mixture of leakage air, entrained particles, and motive air to a storage vessel's top. If your conveying system is operating at less than 5 psig, you may consider injecting the mixture into the conveying line.

## 6 Airlock body vent

Rather than a leakage-handling *method*, the body vent (also called a *boss vent*) is a feature — a port in the airlock housing — added to the rotary airlock valve to release leakage air from the rotor pockets, as shown in Figure 7. Two airlock sources contribute to the total volume of leakage air. One is air leaking through the rotor-tip-to-housing clearance (Figure 1). The other is pressurization of the empty rotor pocket's air volume up to the conveying pressure, which happens before the pocket reaches the material inlet at the airlock's top center, and the volume's expansion back to atmospheric conditions, which happens when the pocket reaches the inlet. The body vent releases

Figure 6

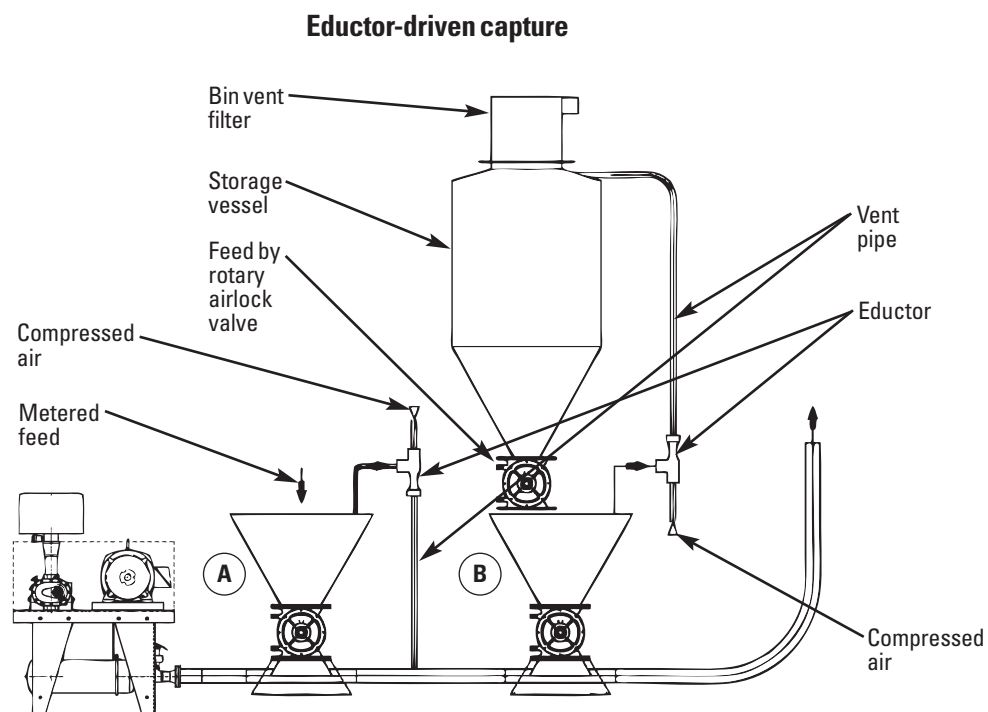

the pressurized rotor pocket's air volume before the pocket rotates back to airlock inlet.

**Figure 7**

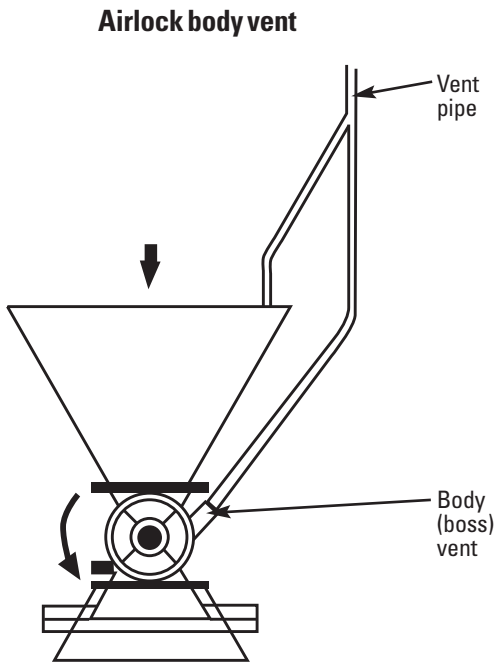

**Benefits.** The rotor pockets in a larger airlock can contain a large volume of pressurized air, which impedes material flow into the airlock's material inlet. Releasing this air from each pocket through the body vent, before the pocket rotates up to the inlet, can minimize this problem. This early air release is also a benefit for an airlock operating in a conveying system at 12 psig or higher pressure, where otherwise the sudden release of pressurized air from each pocket creates a large, disruptive pulse in the material flow into the conveying line. The early air release also increases the fill efficiency of an airlock rotating at high speed (18 rpm or faster), in which each pocket has a shorter exposure time to receive material at the airlock's inlet.

**Risks.** The body vent removes a small portion of the sealing wall between the rotor tips and housing inside the airlock and can lead to a somewhat higher leakage air volume than in an airlock without a body vent. Another problem is that any material that fails to feed from the airlock's bottom outlet into the conveying line is likely to be released through the body vent with the leakage air.

**Recommendations.** Use the body vent with a conveying system handling pellets, granules, or powders in an application where the rotary airlock valve is especially large (greater than 2.5 cubic feet per revolution), rotates at 18

**Table I**

**Recommended methods for handling leakage air in pressure pneumatic conveying applications**

Method	Application (material, feeding method, and conveying system operating pressure)												
	Pellets				Granules				Powder				
	Metered		Flood-fed		Metered		Flood-fed		In fluidized state		In unfluidized state		
	<8 psig	>8 psig	<8 psig	>8 psig	<8 psig	>8 psig	<8 psig	>8 psig	<8 psig	>8 psig	<8 psig	>8 psig	
1 Direct connection to storage vessel													
2 Vented surge hopper													
3 Vent pipe to storage vessel top													
4 Central dust collection													
5 Eductor-driven capture <sup>1</sup>													
6 Airlock body vent													

<sup>1</sup>Note: Arrange the eductor to inject the leakage air, entrained particles, and motive air into the conveying line only with a conveying system operating at less than 5 psig.

rpm or faster, or operates at a differential pressure of 12 psig or higher. (A piston-flow dense-phase conveying system usually has a body vent because of its elevated operating pressure.) You can also use this method in combination with any of the previously discussed methods for venting airlock leakage.

### **Making a choice**

While the methods for handling rotary airlock leakage discussed here cover many types of pressure pneumatic conveying applications, the varieties of materials being conveyed in today's bulk solids plants and the processes in which conveying systems operate are virtually infinite. For this reason, consider the recommendations for each method as general guidelines to help you avoid common mistakes in solving airlock leakage problems.

To choose a venting solution that will work well in your application, use what you've learned in this article to initiate a discussion with your plant engineer and the engineering company or pneumatic conveying supplier that will design and install your conveying system. Table I can be a helpful tool during this process. This table summarizes the recommendations for each method and provides more detail about suitable applications for each. If you find that more than one method is suitable, consider the cost, ease of implementation, and related factors for each to determine which method is best for your plant.

For some applications listed in Table I, few or no methods for handling leakage air are recommended, which means that you may need to modify your application to solve the problem. For instance, no method is recommended for a conveying system handling flood-fed unfluidized powder and operating above 8 psig (far right column). In this case, modifying your application — such as by fluidizing the material or adding a metering device to your equipment arrangement — may be the best solution for venting the leakage air.

**PBE**

### **For further reading**

Find more information on rotary airlock valves in articles listed under "Valves" and "Pneumatic conveying" in *Powder and Bulk Engineering's* comprehensive article index at [www.powderbulk.com](http://www.powderbulk.com) and in the December 2007 issue.

---

**Jonathan O. Thorn** is director of technology at MAC Equipment, 7901 Northwest 107th Terrace, Kansas City, MO 64153; 816-891-9300 or 800-821-2476, fax 816-891-8336 ([thornj@macequipment.com](mailto:thornj@macequipment.com), [www.macequipment.com](http://www.macequipment.com)). He holds a masters degree in chemical engineering from the University of Pittsburgh and has 13 years experience in the bulk solids handling industry.